

SPRING TOGGLE ANCHOR

Installation:

**For light duty fixing
in plasterboards and other materials
with cavities**

1 Drill a hole through the material. Use HSS-drill in plasterboards and other porous materials. Insert the Spring Toggle Anchor through the drilled hole. The toggle-wings will jump into place in the cavity

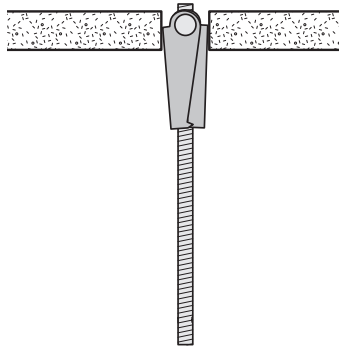

2 Place the fixture and tighten the nut. Avoid over-tightening the Spring Toggle Anchor to prevent damaging the board

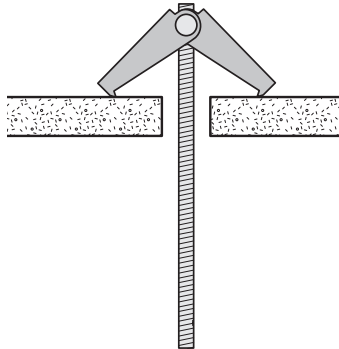

3 The installation is finished

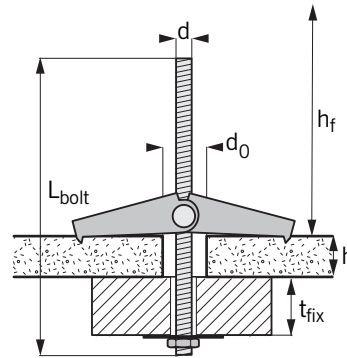
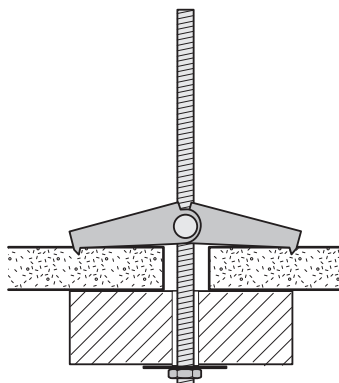

Type	Dimensions			Fixing		Load Capacities
	d	L _{bolt}	h+t _{fix}	d _o	h _f	N _{rec}
Expandet Spring Toggle Anchor mm	Bolt diameter mm	Screw length mm	Thickness of board and fixture (Max.) mm	Drill diameter mm	Cavity (Min.) mm	Recommended tension load kN*
With nut and washer						
3 x 85	M3	85	60	12	28	0,20
4 x 90	M4	90	65	14	35	0,25
With hook						
3 x 70	M3	70	30	12	28	0,03
4 x 70	M4	70	30	14	35	0,10
With cap nut						
3 x 85	M3	85	60	12	28	0,20
4 x 90	M4	90	65	14	35	0,25

* Loads are recommended maximum in plasterboards with 300 mm spacing between each Spring Toggle Anchor. Safety factor is included (≥ 3). 1 kN \approx 100 kg.
Note: Is the recommended spacing not applied the load-capacity will be reduced.
Important: See Expandet's "Principles for fastening" for general information on fastening as well as information on limited liability. (Can be downloaded at www.expandet.com)

Advantages:

Suitable in all materials with cavities.
 All metric threaded screws can be used.
 Fire resistant.

Materials:

Expandet Spring Toggle Anchor is zinc plated min. 5 μ m



EXPANDET SCREW ANCHORS A/S
 Svendebuen 2-6
 DK-3230 Græsted
 Denmark

Telephone: +45 70 22 79 79
 Telefax: +45 70 22 79 89

Version 09.001

www.expandet.com
expandet@expandet.dk

Graphic: Vedkom /Expandet
 ©Expandet Screw Anchors A/S, 2006
 All rights reserved